

WPIDS Derwent World Patent Index® Subscriber File  
 WPINDEX Derwent World Patents Index® Standard File  
 WPIX Derwent World Patents Index® Subscriber File with Extension Abstract  
 Access to WPIDS and WPIX is subject to a relevant subscription with Thomson Reuters (Professional) UK Ltd.

**Subject Coverage** All patent-relevant areas of science and technology. The start of coverage varies by both subject matter and patent authority:

- Pharmaceuticals: 1963
- Plastics and polymers: 1966
- Mechanical, electrical, and general technology: 1974
- Agricultural chemicals: 1965
- All other chemistry and general technology: 1970

**File Type** Bibliographic

**Features**

<p>Thesauri</p> <p><a href="#">Alerts (SDIs)</a></p> <p><a href="#">CAS Registry Numbers®</a></p> <p><a href="#">Keep &amp; Share</a></p> <p>Learning Database</p>	<p>European Patent Classification (/EPC), F-Term (/FTERM), FI-Term (/FCL), ICO (in-computer-only) Classification (/ICO), International Patent Classification (/IPC), Manual Code (/MC), Polymer Indexing Enhanced (/PLE), Title Terms (/TT), and US National Patent Classification (/NCL). There is a thesaurus-like feature in the Compound Number (/DCN), Registry Number (/DRN), Patent Assignee Code (/PACO), and Plasdac Key Serials (/KS)</p> <p>Monthly, weekly, or with each update (1-2 updates per week) (every update is the default)</p> <p><input type="checkbox"/> Page Images</p> <p><input checked="" type="checkbox"/> <a href="#">SLART</a></p> <p><input checked="" type="checkbox"/> Structures</p>	<p><a href="#">STN AnaVist</a> <input checked="" type="checkbox"/></p> <p><a href="#">STN Easy</a> <input checked="" type="checkbox"/></p> <p><a href="#">STN Viewer</a> <input type="checkbox"/></p>
--	---	---

**Record Content** Bibliographic Records

- Patent family data available for each bibliographic record:
  - Basic patent
  - Equivalentents (information about the same invention issued in other countries)
- Invention Level: bibliographic data and Thomson Reuters (Professional) UK Ltd. value-added titles, abstracts, general and (where appropriate) in-depth chemical and electrical indexing. Electrical, engineering drawings and chemical structure drawings. Data from the individual member patents is collated and de-duplicated.
- Member Patent Level (Publication Level): bibliographic data, equivalent abstracts and general indexing information associated with individual documents in the patent family. Additional first-level elements comprise author titles and abstracts, claims, original inventor, patent assignee and agent information including addresses.
- The Invention and Member Patent Levels can be searched individually or in combination.
- Certain features are restricted to eligible users holding an appropriate subscription. WPIDS users with the appropriate level of subscription are entitled to search for special indexing like chemical, polymer coding, or chemical manual codes. WPIX subscribers can also access display of abstract extensions, documentation abstracts, and XML download links.
- Numeric values of 55 physical and chemical properties in almost 400 unit variants are searchable in all English text fields (titles, abstracts, claims).

**WPIDS / WPINDEX / WPIX**

## Structure Records

- Structure searchable chemical repository including substance identification and indexing linked to the corresponding bibliographic records

**File Size**

- More than 21.7 million records with more than 14.3 million images (04/2012)

**Coverage**

- 1963-present
- Electrical and engineering drawings: 1988-present
- Chemical structure drawings 1992-present

**Updates**

Updated every 3 or 4 days with about 16,500 new records (Basic Patents), about 23,000 Equivalents, Polymer and Chemical Coding, and about 14,000 images (technical drawings and chemical structure drawings)

**Language**

English

**Database Producer**

Thomson Reuters (Professional) UK Ltd.  
 The Johnson Building  
 77 Hatton Garden  
 London EC1N 8JS  
 Phone: +44 20 7433 4000  
 Fax: +44 20 7433 4001  
 Helpdesk: +44 20 7433 4999  
 E-mail: ts.support.emea@thomsonreuters.com  
 United Kingdom  
 Copyright Holder: Thomson Reuters

**Sources**

Patent documents are covered from:

Argentina (1975)*	Malaysia (2010-present)
Australia (1963-69,1983-pres.)	Mexico (1997-present)
Austria (1975-present)	Netherlands (1963-present)
Belgium (1963-present)	New Zealand (1993-present)
Brazil (1976-present)	Norway (1974-present)
Canada (1963-present)	PCT (WIPO) (1978-present)
China (1987-present)	Philippines (1994-present)
Czech Republic (1994-present)	Poland (2011-present)
Czechoslovakia (1975-1994)*	Portugal (1974-present)
Denmark (1974-present)	Rep. of Korea (1986-present)
European Pat. Off. (1978-present)	Romania (1975-present)
Finland (1974-present)	Russian Federation (1994-present)
France (1963-present)	Singapore (1995-present)
Germany (1963-present)	Slovakia (1994-present)
Germany (Utility Models) (1995-present)	South Africa (1963-present)
German (Dem. Rep.) (1963-1990)	Soviet Union (1963-1994)*
Gulf Cooperation Council (2011-present)	Spain (1983-present)
Hong Kong (2011-present)	Sweden (1974-present)
Hungary (1975-present)	Switzerland (1963-present)
India (2004-present)	Taiwan (1993-present)
Ireland (1963-69,1995-pres.)	Thailand (2010-present)
Israel (1975-present)	United Kingdom (1963-present)
Italy (1966-69,1978-present)	United States (1963-present)
Japan (1963-present)	Vietnam (2010-present)
Luxembourg (1984-present)	

Additional Sources are:

- Research Disclosure (1978-present)  
Copyright: Kenneth Mason Publications Limited [2006] www.researchdisclosure.com
- International Technology Disclosures (1984-93)\*  
\* signifies available within the backfile only

---

## Sources (cont.)

Additional first level data elements such as original titles and abstracts, claims, inventor, assignee and agent information and addresses may be present at the Member Patent Level as follows:

- Australia (2004-present)
- Germany (1968-present)
- European Patent Office (1978-present)
- Japan (1975-present)
- PCT (WIPO) (1978-present)
- United Kingdom (1984-1997, 2004-present)
- United States (1975-present)

Comprehensive details of coverage within Derwent World Patents Index (R) can be found within Global Patent Sources which is available to download for free at:  
<http://scientific.thomson.com/products/gps/>

---

## User Aids

- Derwent World Patents Index STN Online User Guide
  - STNGUIDE
  - Online Helps (HELP DIRECTORY lists all help messages available)
  - Patent Sources \*
  - Introduction to Chemical Indexing
  - Classification User Guide \*
  - Title Terms User Guide \*
  - Patentee Codes User Guide \*
  - CPI Chemical Indexing Guidelines, Indexing of Chemical and Pharmaceutical Patents \*
  - CPI Chemical Indexing User Guide \*
  - CPI Manual Codes User Guide \*
  - Chemistry Resource on STN \*
  - CPI Plasdoc Coding Systems User Guide \*
  - Polymer Indexing Directory Parts 1 and 2 \*
  - Polymer Indexing Reference Manual \*
  - Polymer Indexing System Description User Guide \*
  - Polymer Indexing Thesaurus Guide \*
  - Polymer Indexing Hierarchy User Guide \*
  - EPI Manual Codes User Guide Parts 1,2 and 3 \*
- \* Available from the producer

---

## Clusters

- 2ANAVIST
  - 2HANAVIST
  - AEROTECH
  - ALLBIB
  - AUTHORS
  - BIOSCIENCE
  - CORPSOURCE
  - ENGINEERING
  - FORMULATIONS
  - HPATENTS
  - PATENTS
  - POLYMERS
- [STN Database Clusters](#) information (PDF)

---

## Related Databases

- LWPI

---

## Pricing

See the [STN Price List](#) or enter HELP COST at an arrow prompt.

## Search and Display Field Codes

Fields that allow left truncation are indicated by an asterisk (\*).

### General Search Fields

Search Field Name	Search Code	Search Examples	Display Codes
Basic Index* (contains single words from AB, ABDT, ABEQ, ABEX, ACTN, ACTV, ADV, ALE, DETD, DRWD, NOV, TECH, TI, TT, UADV, and USE)	None or /BI (or /BIX)	S DRILLING FLUID AND EMULS? S ?PHENYLETHER? S #####DIPHENYLETHER S ULCER TREATMENT(L)ORAL	AB, ABDT, ABEQ, ABEX, ACTN, ACTV, ADV, ALE, DETD, DRWD, NOV, TECH, TI, TT, UADV, USE
Abstract *(contains value-added data) Abstract, Documentation Type (1) Abstract, Extension* (2) Accession Number  Accession Number Week, Supplement Activity Advantage Application Country (3) Application Date (3,4) Application Number (3,5)  Application Number Year (4) Application Type Application Year (3,4) Country Count (4) Cross Reference  Crossover Accession Number Designated State (6)  Detailed Description* Document Level Document Number CPI Document Number Non CPI Document Type Drawing Description* Number of Drawings (4) DWPI Class (7)  DWPI Update (4) DWPI Week (4,6)  DWPI Week, Basic (4,6) Entry Date (4) European Patent Classification (8)  European Patent Classification Keywords Field Availability  File Segment	/AB  /ABDT /ABEX /AN  /DW.AN  /ACTV /ADV /AC /AD /AP  /AP.YR /APT /AY /CYC /CR (or /XR) /ANX /DS  /DETD /DLVL /DNC /DNN /DT /DRWD /DRWN /DC  /DUPD /DW  /DW.B /ED /EPC (or /ECLA, or /EPCLA /EPC.KW  /FA  /FS	S OSTEOGENIC PROTEIN?/AB  S (DNA AND PROTEIN)/ABDT S ?FERMENT?/ABEX S 2008-B12345/AN S 2007-894520/AN S 197022/DW.AN  S ANTIBIOTIC ACTIVITY/ACTV S LASER BEAM?/ADV S GB/AC(P)1990/AY S JAN 1993-APR 1993/AD(S)FR/AC S 1989GB-000219641/AP S GB1989-219641/AP S 2004/AP.YR S RELATED TO/APT S 1990-1991/AY S 20-30/CYC S 1990-001459/CR S 1990-001459/AN,CR S 1980-B7362C/ANX S BE/DS S RW: BE/DS(P)1990/PY S NAPHTHALENE?/DETD S L1 AND INVENTION/DLVL S C1993-056092/DNC S N1983-041955/DNN S L7 AND P/DT S ?TANGUL?/DRWD S DRWN=9 S A25/DC S A/DC S 197007/DUPD S 199108/DW S 199301-199315/DW(P)FR/PC S 199315/DW.B(P)US/PC.B S ED>19940201 AND L10 S A01B0015-20/EPC  S D2/EPC.KW  S L7 NOT NOAB/FA S L11 AND GI/FA S PLASMA AND EPI/FS	AB  ABDT ABEX AN  AN  AB, ACTV AB, ADV ADT, AI ADT, AI ADT, AI  ADT, AI ADT, AI ADT, AI CYC CR  PI  AB, DETD not displayed DNC DNN not displayed AB, DRWD DRWN DC  DUPD PI  PI, PI.B ED EPC  EPC  FA  FS

## General Search Fields (cont'd)

Search Field Name	Search Code	Search Examples	Display Codes
Filing Details <b>(5,6)</b>	/FDT	S US5072794/FDT S EP-----105613/FDT	FDT
Filing Details, Patent Country (WIPO code and text)	/FDT.PC (or /RLPC)	S CANADA/FDT.PC S CA/FDT.PC	FDT
Filing Details, Patent Kind	/FDT.PK (or /RLPK)	S CAA/FDT.PK	FDT
Filing Details, Patent Number	/FDT.PN (or /RLPN)	S CA1248729/FDT.PN	FDT
Filing Details, Type ICO (in-computer-only)	/FDT.TP /ICO	S REISSUE OF/FDT.TP S K61M/ICO	FDT ICO
International Patent Classification (contains ICM and ICS)	/IC	S C09K007/IC S C09K007-02/IC S C09K007-02/IC S D01D005-08?/IC	PI, IC
International Patent Classification (ICA, ICI, ICM, ICS, IPCI, IPCR) <b>(8)</b>	/IPC	S C12P021-08/IPC	IPC
Inventor	/IN (or /AU)	S HALE, A H/IN S HALE A H/IN,PA	IN
IPC Keyword Terms	/IPC.KW	S ADDITIONAL/IPC.KW	IPC.TAB
IPC Reform	/IPC.REF	S A01B0003-44/IPC.REF	IPCI, IPCR
IPC, Action Date <b>(4)</b>	/IPC.ACD	S IPC.ACD>20070107	IPC.TAB
IPC, Additional (supplementary)	/ICA	S A01K067-027/ICA	ICA
IPC, Index (complementary)	/ICI	S B03D103:08/ICI	ICI
IPC, Main <b>(7)</b>	/ICM	S C09K007-02/ICM	PI, IC
IPC, Secondary	/ICS	S D01B001-38/ICS	IC
IPC, Version <b>(5)</b>	/IPC.VER	S 20080101/IPC.VER	IPC.TAB
Japanese Patent Office Classification (FI Class) (Additional)	/FACL	S A01B001/FACL	FCL
Japanese Patent Office Classification (FI Class) (Index)	/FICL	S A61K0031:045/FICL	FCL
Japanese Patent Office Classification (FI Class) (Main)	/FMCL	S H01B0001-02/FMCL	FCL
Japanese Patent Office Classification (FI Class) (Secondary)	/FSCL	S H05K0013-08 Z/FSCL	FCL
Japanese Patent Office Classification (FI or File Index) <b>(8)</b>	/FCL	S A61K0006-00 A/FCL	FCL
Japanese Patent Office Classification (FTERM or File Forming Term) <b>(8)</b>	/FTRM (or /FTERM, or /FTCLA, or /JPCLA)	S 5B001/AA01/FTRM	FTRM
Language (ISO code and text)	/LA	S FR/LA(P)EP/PC AND L3 S FRENCH/LA(P)EP/PC(P)1990/PY S C09K/ICM(T)18-20/MGR	PI
Main Group of IPC Version 1-7 Range Searchable <b>(4)</b>	/MGR		not displayed
Manual Code <b>(8,9)</b>	/MC	S A12-W10A/MC	MC
Markush Compound Number	/MCN	S 0153-12201-CL/MCN	MCN, CMC
Mechanism of Action*	/ACTN	S CYTOKINES/ACTN	AB, ACTN
Novelty* <b>(11)</b>	/NOV	S EXCITATION LIGHT/NOV	NOV
Number of Pages <b>(4)</b>	/PGN	S PGN=5 AND L2	PI
Patent Assignee <b>(10)</b>	/PA (or /CS)	S SHELL OIL/PA S "NEW YORK WIRE"?/PA	PA

## General Search Fields (cont'd)

Search Field Name	Search Code	Search Examples	Display Codes
Patent Assignee Code (8,12) Patent Country (6,13)	/PACO /PC	S SHEL/PACO S GB/PC(P)1989/AY S UNITED KINGDOM/PC	PA PI
Patent Country, Basic (6,13) Patent Kind Code (6,14)	/PC.B /PK	S GB/PC.B(P)JUNE 1992/PD.B S GBA/PK S EPA2/PK(P)DE/DS	PI PI
Patent Kind Code, Basic (6,14)	/PK.B	S EPA/PK.B S EPA1/PK.B(P)1991-1992/PY.B	
Patent Number (5,6)	/PN	S US5198416/PN S EP-----100323/PN S EP0100323/PN S EP100323/PN S US20060000001/PN S US-20060000001/PN S US,100,503/PN	PI
Patent Number, Basic (5,6)	/PN.B	S US5198416/PN.B	PI
Patent Number Count (4)	/PNC	S 5-10/PNC	PNC
Patent Number/Kind Code	/PNK	S WO2009006253A2/PNK	PNK
Patent Number/Kind Code, Basic	/PNK.B	S TH43458A/PNK.B	PNK.B
Patent Publication Type	/PT	S EQUIVALENT/PT AND BE/PC	PI
Priority Application Number, First	/PRNF	S AL1961-8036/PRNF	PRAI
Priority Country (15)	/PRC	S FR/PRC S GB/PRC(S)1990/PRY	PRAI PRAI
Priority Country, First	/PRCF	S AU/PRCF	PRAI
Priority Date (4,15)	/PRD	S 19880930/PRD S JUNE 1991/PRD(S)FR/PRC	PRAI PRAI
Priority Date, First (4,15)	/PRDF	S JUNE 1991/PRDF	PRAI
Priority Number (5,15)	/PRN	S 1988US-000252206/PRN S US1988-252206/PRN S 1990DE-0000010670/PRN S DE1990-10670/PRN	PRAI PRAI
Priority Number, Year (4)	/PRN.YR	S 2005/PRN.YR	PRAI
Priority Year (4,15)	/PRY	S 1990-1991/PRY(S)NL/PRC	PRAI
Priority Year, First (4,15)	/PRYF	S 1992/PRYF	PRAI
Publication Date (4,6)	/PD	S 19900404/PD S 1 APR 1990-15 APR 1990/PD(P)GB/PC	PI
Publication Date, Basic (4,6)	/PD.B	S 19930330/PD.B(P)US/PC.B	PI
Publication Year (4,6)	/PY	S 1990-1991/PY	PI
Publication Year, Basic (4,6)	/PY.B	S 1990/PY.B(P)JP/PC.B	PI
Sub Group of IPC Version 1-7 Range Searchable (4)	/SGR	S C09K007/ICM(T)100-2000/SGR S F01B-007/IC(T)10000-12000/SGR	not displayed
Summary Language (ISO code and text)	/SL	S L1 AND EN/SL	SL
Technology* (11)	/TECH	S DYEING AGENT#/TECH,BI	TECH
Title*	/TI	S DRILLING FLUID#/TI	TI
Title Terms (16) (incl. Additional Words)	/TT	S DRILL/TT S FIBRE-OPTIC/TT	TT
Update Date (4)	/UP	S JAN 2007/UP	UP
Update Date Abstract (4)	/UPAB	S FEB 2009/UPAB	UPA
Update Date Chemical Code (4)	/UPB	S UPB=APR 2005	UPB
Update Date Documentation Abstract (4)	/UPDA	S MAR 2006/UPDA	UPDA
Update Date Equivalent (4)	/UPEQ	S UPEQ=AUG 2006	not displayed
Update Date Graphic Image (4)	/UPGI	S UPGI=APR 2005	not displayed
Update Date Index Terms (4)	/UPIT	S 20050412/UPIT	UPIT
Update Date International Patent Classification Code	/UPIC	S 20090918/UPIC	UPIC

## General Search Fields (cont'd)

Search Field Name	Search Code	Search Examples	Display Codes
Update Date Patent Assignee (4)	/UPPA	S 20050426/UPPA AND L15	UPPA
Update Date Patent Family (4)	/UPP	S FEB 1994-APR 1994/UPP	UPP
Update Date Patent Information (4)	/UPPI	S UPPI=JAN 2006	UPPI
Update Date Polymer Indexing (4)	/UPA	S UPA=APR 2005	UPA
Update Date Priority Information (4)	/UPPR	S UPPR>=APR 2008	UPPR
Update Date Enhanced Title (4)	/UPTI	S 20050422/UPTI AND L2	UPTI
US National Patent Classification, Current (8)	/NCL	S 002006100/NCL	NCL
US National Patent Classification, Current (main)	/NCLM	S 002/NCLM	NCL
US National Patent Classification, Current (secondary)	/NCLS	S 004/NCLS	NCL
Use Section*	/USE	S (SYNTHESIS AND BIOSYNTHETIC)/ USE S ?PHENYLETHER?/USE	USE
Use/Advantage Section	/UADV	S TREATMENT/UADV	UADV

- (1) This field is displayable in WPIX only. Available for 1995-1999.
- (2) This field is displayable in WPIX only. Available from update 199908 onwards.
- (3) Application Information is linked by (P) proximity to the patent information of the respective document.
- (4) Numeric search field that may be searched using numeric operators or ranges.
- (5) Numbers are searchable in DWPI and STN format.
- (6) Patent information (PN, PC, PK only) and application information of one patent document is linked by (P) proximity.
- (7) The classification text of DWPI classes is available in abbreviated form for EXPAND, however not for SEARCH
- (8) A thesaurus is available in this field.
- (9) DWPI manual codes automatically echo each search term and its definition when you search.
- (10) Search with implied (S) proximity is available in this field. Bound phrases have to be searched with quotation marks.
- (11) Available from Update 199908 onwards.
- (12) The list of Thomson Reuters (Professional) UK Ltd.-assigned company codes for patent assignees matched with company names is available in this field. See page 12.
- (13) Enter HELP COUNTRY online for detailed coverage information.
- (14) Enter HELP KIND online for definitions of the patent document kind codes.
- (15) Priority information referring to the same application is linked by (P) proximity.
- (17) A function for preferred and forbidden terms (USE, UF relationship) is available for EXPAND and SEARCH in this field – see 'DWPI Title Terms' on page 11. By default, the preferred term is searched, when a forbidden one is part of the query

## Super Search Fields

Enter a super search code to execute a search in one or more fields that may contain the desired information. Super search fields facilitate crossfile and multifile searching. EXPAND may not be used with super search fields. Use EXPAND with the individual field codes instead.

Search Field Name	Search Code	Fields Searched	Search Examples	Display Codes
Application Number Group (1)	/APPS	/AP, /PRN	S 1989GB-0219641/APPS S 1989GB-0219641/APPS	ADT, AI, PRAI
Document Number	/DN	/DNC, /DNN	C1993-056092/DN	DNC, DNN
Patent Number Group (2)	/PATS	/FDT, /PN	S GB2223255/PATS S EP-----100323/PATS S EP100323/PATS	FDT, PI
Patent Countries	/PCS	/PC, /DS	S ES/PCS S SPAIN/PCS	DS, PI

- (1) Either STN or Derwent format may be used.
- (2) Enter HELP COUNTRY for detailed coverage information.

## Additional DWPI individual patent publication (often First Level Data) Search Fields

Fields that allow left truncation are indicated by an asterisk (\*).

Search Field Name	Search Code	Search Examples	Display Codes
Basic Index Extended* (contains single terms from author abstracts, claims, and titles)	/BIEX	S NANOCLUSTERS/BIEX	ABDE, ABEN, , ABFR, CLMEN, CLMDE, CLMFR, TIDE, TIEN, TIES, TIFR
Abstract, Original, in English*	/ABEN	S ?CONDUCTIVE MATERIAL/ABEN	ABEN
Abstract, Original, in French*	/ABFR	S ?MOBILIS?/ABFR	ABFR
Abstract, Original, in German*	/ABDE	S ?AUTOMATISIERT?/ABDE	ABDE
Accession Number, Publication Level	/AN.PUB	S 2005-262794/AN.PUB	AN
Agent	/AG	S PFIZER/AG	AG
Agent Address	/AGA	S NEWCASTLE/AGA	AGA
Agent Address, City	/AGA.CTY	S (MUNICH OR MUENCHEN)/AGA.CTY	AGA
Agent Address, Country (code)	/AGA.CNY	S NL/AGA.CNY	AGA
Agent, Total	/AG.T	S PFIZER INC./AG.T	AG.T
Application Information, Thomson Reuters (Professional) UK Ltd.	/APTS	S 1978US-000000357/APTS	APTS
Claims *	/CLM	S OFFICE CHAIR/CLM S BUEROSTUHL/CLM S ?CHAIR?/CLM	CLMEN, CLMDE, CLMFR
Field Availability	/FA.M	S ABDT/FA.M	FA
Initial IPC (ICM, ICS)	/IIC	S A01B000/IIC	IIC
Initial IPC, Additional (supplementary)	/IICA	S A01B003-36/IICA	IICA
Initial IPC, Index (complementary)	/IICI	S B03D103:08/IICI	IICI
Initial IPC, Main	/IICM	S C09K007-02/IICM	IIC
Initial IPC, Secondary	/IICS	S A01B001/IICS	IIC
International Patent Classification (IIC, IICA, IICI, IICM, IICS)	/IPC	S A01B003-36/IPC	IIC, IICA, IICI, IICM, IICS
Inventor Address	/INA	S HEIDELBERG/INA	INA
Inventor Address, City	/INA.CTY	S WIEN/INA.CTY	INA
Inventor Address, Country (code)	/INA.CNY	S DE/INA.CNY	INA
Inventor, Original	/INO	S MAYER DALE J/INO	INO
Inventor, Residence (WIPO Code)	/IN.RES	S BE/IN.RES	INA
Inventor, Nationality (WIPO Code)	/IN.NAT	S AT/IN.NAT	INA
Inventor, Total	/IN.T	S MAYER?/IN.T	IN.T
National Classification, Issued	/INCL	S D01125000/INCL	INCL
National Classification, Issued (secondary)	/INCLS	S PLT001000/INCLS	
National Classification, Issued (main)	/INCLM	S D24225000/INCLM	INCL
Patent Assignee Address	/PAA	S MUENCHEN?/PAA	PAA
Patent Assignee Address, City	/PAA.CTY	S MUNICH/PAA.CTY	PAA
Patent Assignee Address, Country (WIPO code)	/PAA.CNY	S BE/PAA.CNY	PAA
Patent Assignee, Limitation (WIPO code)	/PA.LIM	S DE/PA.LIM	MEMB, MEMBF
Patent Assignee, Nationality (WIPO code)	/PA.NAT	S BE/PA.NAT	MEMB, MEMBF
Patent Assignee, Original	/PAO	S 3M COMPANY/PAO	PAO
Patent Assignee, Residence (WIPO code)	/PA.RES	S DE/PA.RES	MEMB, MEMBF

## Additional DWPI individual patent publication (often First Level Data) Search Fields

Search Field Name	Search Code	Search Examples	Display Codes
Patent Assignee, Total	/PA.T	S BASF AG/PA.T	PA.T
Priority Country, Basic (WIPO code and text)	/PRC.B	S AR/PRC.B	PRAI
Priority Application Information, Thomson Reuters (Professional) UK Ltd.	/PRTS	S 1998AR-000100591/PRTS	PRTS
Priority Date, Basic (1)	/PRD.B	S PRD.B=JUN 1998	PRAI
Priority Number, Basic	/PRN.B	S AR1968-214388/PRN.B	PRAI
Priority Year, Basic (1)	/PRY.B	S 1998/PRY.B	PRAI
Summary Language (WIPO code and text)	/SL.M	S FR/SL.M	
Title Language (WIPO code and text)	/TL	S L1 AND EN/TL	TL
Title, Original, in English	/TIEN	S PLANT PRODUCT/TIEN	TIEN
Title, Original, in French	/TIFR	S FRUIT#/TIFR	TIFR
Title, Original, in German	/TIDE	S FRUCHTFLEISCH/TIDE	TIDE
Title, Original, in Spanish	/TIES	S FRUTOS/TIES	TIES
Update Date Author Abstract (1)	/UPAA	S MAR 2006/UPAA	not displayed
Update Date Author Title (1)	/UPAT	S 16 APR 2005/UPAT	not displayed
Update Date Claims (1)	/UPCL	S 20050509/UPCL	not displayed
Update Date International Patent Classification, Original (1)	/UPIO	S UPIO=12 APR 2005	not displayed
Update Date USPTO Classification, Original (1)	/UPNO	S UPNO=20050416	not displayed

(1) Numeric search field that may be searched using numeric operators or ranges.

## Chemistry Resource Segment Search and Display Fields

Fields that allow left truncation are indicated by an asterisk (\*).

Search Field Name	Search Code	Search Examples	Display Codes
Chemical Name	/CN	S MANDELIC ACID/CN	CN
Chemical Name Segment* (from CN.P, CN.S, SY)	/CNS	S DISULFONYL DIAZIDE/CNS	
Chemical Name, Preferred	/CN.P	S D-GLUCOSE-6-PHOSPHATE/CN.P	CN.P
Chemical Name, Systematic	/CN.S	S DECANE-1,10-DISULFONYL DIAZIDE/CN.S	
Chemistry Resource Accession Number, Chemistry Resource Segment	/AN.S	S DCR-100174/AN.S	AN.S
Chemistry Resource Number, Chemistry Resource Segment	/DCSE	S 70-0-0-0/DCSE	DCSE
Classification Code (Substance Descriptor)	/CC	S HALOCARBONS/CC	CC
Comment	/CMT	S FIBROBLAST#/CMT	CMT
Component Molecular Formula	/CMF (or /FRAGMF)	S C H3 F6 P *1/CMF	SMF
Controlled Term	/CT	S MAO-INHIBITOR/CT	CT
Controlled Term, Drug Activity	/CT.DA	S MAP-KINASE-INH*/CT.DA	CT
Controlled Term, Mechanism of Action	/CT.MA	S ADRENALINE/CT.MA	CT
Derwent Drug Registry Name	/DDRN	S GALACTOSE/DDRN	DDRN
Element Symbol	/ELS	S (N AND S)/ELS	SMF
Element Symbol, Count (1)	/ELS.CNT	S O/ELS(S)7/ELS.CNT	SMF
Entry Date Chemistry Resource (1)	/EDCR	S 19 JUL 1999/EDCR	EDCR

## Chemistry Resource Segment Search and Display Fields (cont'd)

Search Field Name	Search Code	Search Examples	Display Codes
Fragment Molecular Formula	/FRAGMF (or /CMF)	S AL *154/FRAGMF	
Molecular Formula	/MF	S H CL2 N/MF	MF
Molecular Weight (1)	/MW	S 17-21/MW	MW
Number of Components (1)	/NC	S 9-11/NC	
Number of Fragments (1)	/NFRAG	S 4/NFRAG AND L11	SMF
Standardized Molecular Formula	/SMF	S "B *1; SI *1; TOTAL *2; TYPE *2"/SMF	SMF
Substructure Terms	/SS	S PHOSPHONIC-ACID/SS	SS
Structure Cross Reference	/SCR (or /SXR)	S 104403 : SEE ALSO/SCR	SCR
Structure Segment DWPI Compound Number (2)	/SDCN	S R20123/SDCN	SDCN
Structure Segment DWPI Registry Number (2)	/SDRN	S 1029/SDRN	SDRN
Structure Segment Ring (2)	/SRIN	S 11895/SRIN	
Synonym Name	/SY	S FALUBIN/SY	SY
Update Date DWPI Chemistry Resource (1,3)	/UPCR	S JAN 2000/UPCR	UPCR
Update Date DWPI Cross Reference (1,4)	/UPWX	S 19990719/UPWX	UPWX

(1) Numeric search field that may be searched with numeric operators or ranges.

(2) Cross reference to indexing in bibliographic records. Select data from SDCN or SDRN or SRIN and search in /DCN resp. /DRN, resp. /RIN to retrieve bibliographic records.

(3) UPCR is created when new compounds enter the Chemistry Resource Segment.

(4) UPWX is created when DCR compounds are cited in bibliographic records. UPWX is used in automatic current awareness searches (SDIs) in the Chemistry Resource Segment.

## Chemical and Polymer Indexing (see also Chemistry Resource)

Search Field Name	Search Code	Search Examples	Display Codes
DWPI Class (1)	/DC	S A25/DC	DC
DWPI Compound Number (Specific Compound Number) (2)	/DCN	S R10034-M/DCN S R10034/DCN S R10034+UF/DCN	CMC, DCN
Chemistry Resource Accession Number, Bibliographic Segment (3)	/DCR	S L10/DCR	DCR
DWPI Registry Number (4)	/DRN	S 5107-U/DRN S 5107/DRN S CAPROPYL PEROXIDE+USE/DRN	DRN
Fragment Code (PLASDOC) (5,6)	/FG	S 503 54& 600 609/FG	PLC
Index Term (incl. DCR numbers) (7)	/IT	S 7-PRD/IT S (87874(T)PRD)/IT	IT
Plasdoc Key Serials (5,6,8,9)	/KS	S 2017 2020 2296 2575/KS S L10/DCR(t)PRD/KW	PLC
Manual Code (10)	/MC	S A12-W10A/MC	MC
Markush Compound Number	/MCN	S 8944-01501-P/MCN	CMC, MCN
Chemical Codes (6)	/M0-/M6	S B713 G012 H600 L399 M903/M3	CMC
Polymer Indexing Enhanced (11)	/PLE	S (G1854(S)D10)/PLE S ((P0737(P)S1672)(L)B4171)/PLE	PLE
Ring Index Number (12)	/RIN	S 50736/RIN	CMC
Update Date Polymer Indexing (13)	/UPA	S L4 AND MAR 2005/UPA	UPA
Update Date Chemical Code (13)	/UPB	S UPB=21 APR 2005	UPB
Update Date Keyword Indexing (13)	/UPIT	S UPIT=MAY 2008	UPIT

## Chemical and Polymer Indexing (see also Chemistry Resource) (cont'd)

- (1) The classification text of DWPI classes is available in abbreviated form for EXPAND, however not for SEARCH.
- (2) DWPI compound numbers are linked by (P) proximity to the relevant M1-M6 chemical codes with which they display. They can be searched directly in the Chemical Codes (/Mx) fields. The definition of DCNs is available online with the EXPAND command. Enter code +UF/DCN to see the definition of the DCN represented by 'code'. Text +USE/DCN shows the DCN code to be used for the definition represented by 'text'.
- (3) Field /DCR is used to retrieve records from the bibliographic segment using a search result from the Chemistry Resource Segment. Example: => S L10/DCR. L10 is the result of a search in segment Chemistry Resource. L10/DCR retrieves bibliographic records, where the compounds of L10 are cited.
- (4) The definition of DRNs is available online with the EXPAND command. Enter code +UF/DRN to see the definition of the DRN represented by 'code'. Text +USE/DRN shows the DRN code to be used for the definition represented by 'text'.
- (5) Search with implied (P) proximity is available in this field.
- (6) Fields /FG and /KS were discontinued as of DWPI update 199401 being replaced by field /PLE.
- (7) Contains DCR Numbers and roles, which are linked by (t) proximity. See => HELP ROLES for an explanation of the role codes.
- (8) The Plasdoc Key Serials Codes can be looked up in an online thesaurus – see page 13.
- (9) When using Key Serials Codes in a search in field /KS, the codes are echoed, i.e., their definitions are shown automatically. Use echoing to check your searches in /KS.
- (10) DWPI manual codes automatically echo each search term and its definition when you search.
- (11) /PLE is available since DWPI update 199332, replacing fields /FG and /KS. There are three levels of linking in this field: tightest – (S), middle – (P), widest – (L) proximity. The Polymer Indexing Thesaurus is available online in /PLE.
- (12) Ring indexing numbers are linked by (P) proximity to the chemical codes in field CMC. Since DWPI update 198601 they are specifically linked to the respective CMC subfield. These specifically linked ring index numbers can be searched directly in the Chemical Codes (/Mx) fields. They display below the respective CMC subfield.
- (13) Numeric search field that may be searched using numeric operators or ranges.

## Structure Searching

The scope of Structure Searches is always the full DCR file segment. Structure Search SDIs are executed in the update portion of the file which contains all DCR structures that have been newly cited in the bibliographic file segment in that week.

Terms	Search Examples
L-numbers of structures built using the STRUCTURE command or uploaded from STN Express or STN on the Web (Boolean logic allowed between L-numbers)	SEARCH L1 FAM SEA L1 AND L2 SSS
L-numbers of screen sets created using the SCREEN command (Boolean logic allowed between the L-numbers)	S L3 OR L4 SSS
L-numbers of structures built using the STRUCTURE command or uploaded from STN Express or STN on the Web combined with L-numbers of screen sets created using the SCREEN command (Boolean logic allowed between the L-numbers)	S L1 AND L2 NOT L3

## Types of Structure Searching

Type	Definition	Search Code	Search Examples
Substructure (default)	Search for substances which match the query. Substitution is allowed at all open positions. Additional components may be retrieved.	SSS	SEARCH L1 SSS S L2 OR L3 SSS S L7 SSS
Closed Substructure	Search for substances which match the query exactly. Substitution is allowed at positions opened by CONNECT. Additional components may be retrieved.	CSS	SEARCH L1 CSS S L2 NOT L3 CSS S L4 OR L5 CSS
Exact Family	Search for substances which match the query exactly. Additional components may be retrieved.	EXA FAM	S L5 EXA FUL S L6 FAM

## Scopes of Structure Searching

The scope of Structure Searches is always the full DCR file segment. Structure Search SDIs are executed in the update portion of the file that contains all DCR structures that have been newly cited in the bibliographic file segment in that week.

Scope	Definition	Search Code	Search Examples
Full Sample (default)	Search 100% of the file Search a fixed 10% of the file	FUL SAM	S L5 OR L8 SSS S L6 SSS SAM
Subset Full	Search 100% of an answer set created by a search in the file	SUB FUL	S L7 SSS SUB=L5 FUL
Subset Sample	Search a fixed sample of an answer set created by a search in the file	SUB SAM	S L7 SSS SUB=L5 SAM

## Property Fields<sup>1)</sup>

In DWPI a numeric search for a specific set of physical properties (/PHP) is available within the English text fields (titles, abstracts, claims). The numeric values are not displayed as single fields, but highlighted within the hit displays.

Use EXPAND/PHP to search for all available physical properties. A search with the respective field codes will be carried out in all database fields with English text. The /PHP index contains a complete list of codes and related text for all physical properties available for numeric search.

Field Code	Property	Unit	Search Examples
/AOS	Amount of substance	Mol	S 10/AOS
/BIR	Bit Rate	Bit (Bit)	S 100000-160000/BIR
/BIT	Stored Information	Bit	S BIT > 3 MEGABIT (10A) STORAGE
/CAP	Capacitance	Farad	S 1-10 MF/CAP
/CDN	Current Density	Ampere/Square Meter	S CDN>10 A/M**2
/CMOL	Molarity (Concentration, amount of substance)	mol/l	S MOLYBD?/BI (S) 2/CMOL
/CON	Conductance	S (Siemens)	S 1E-2/CON
/DB	Decibel	Decibel	S DB>50
/DEG	Degree	Degree	S (POLARI? (S) ANGLE)/BI (S) 45/DEG
/DEN	Density (Mass Density)	Kg/m3	S (CELL? (S) RECOMBIN?)/CLM (S) 5E-3-10E-3/DEN
/DEQ	Dose Equivalent	Sievert	S DEQ>0.5 (S) RADIATION
/DOS	Dosage	Milligram/Kilogram	S DOS>0.8
/DV	Viscosity, dynamic	Pa * s (Pascal * second)	S DV>5000
/ECH	Electric Charge	Coulomb	S 10-15/ECH.EX (XA) CAPACITOR
/ECD	Electric Charge	Coulomb/Square Meter	S 1-20 /ECD.EX (XA) ELECTRICAL
/ECO	Electrical Conductivity	Siemens/Meter	S ECO>1000 (XA) WIRE
/ELC	Electric Current	Ampere	S 1-10/ELC
/ELF	Electric Field	Volt/Meter	S 1-5 /ELF
/ENE	Energy	J (Joule)	S L1 AND 10000/ENE
/ERE	Electrical Resistivity	Ohm * Meter	S ERE>10 (P) ISOLAT?
/FOR	Force	N (Newton)	S 50 N/FOR
/FRE	Frequency	Hz (Hertz)	S ANALY?/CLM (10A) 0-3/FRE
/IU	International Unit	none	S IU>1000 (P) ANTIBIOTIC
/KV	Viscosity, kinematic	m2/s	S LUBRICANT/BI (S) 10E-5/KV

Property Fields<sup>1)</sup> (cont'd)

Field Code	Property	Unit	Search Examples
/LEN (or /SIZ) /LUME	Length Luminous Emittance/Illuminance	Meter Lux	S 1-4/LEN S 10-50/LUME
/LUMF	Luminous Flux (Luminous Power)	Lumen	S L74 (S) LUMF>70
/LUMI	Luminous Intensity	Candela	S 5<LUMI<15
/M	Mass	Kg (Kilogram)	S ALLOY/BI (30A) 1E-10-1E-5/M
/MCH	Mass to Charge Ratio	none	S MCH=3
/MFD (or /MFS)	Magnetic Flux Density	Tesla	S MFD.EX>0E-3 (S) MAGNETC RESONANCE
/MFR (or /MFL)	Mass Flow Rate	Kilogram/Second	S MFR.EX<0E-3
/MM	Molar Mass	g/mol	S 2000-3000 G/MOL/MM
/MOLS	Molality of Substance	mol/kg	S 01.-10 mol/kg/MOLS
/MVR	Melt Volume Rate	none	S 5-10/MVR
/NUC	Nutrition Content	none	S NUC<100 (XW) NUTRIENT
/PER	Percent (Proportionality)	Percent	S (TITAN? (3A) DIOXID?)/CLM (S) 5/PER
/PERA	Permittivity, Absolute	Farad/Meter	S 1-10/PERA (S) BUFFER
/PHV	pH	pH	S 7.4-7.6/PHV
/POW	Power	W (Watt)	S (SOLAR? OR PHOTOVOLTAIC?)/BI (10A) 5-10/POW
/PRES (or /P)	Pressure	Pa (Pascal)	S (VACUUM (5A) DISTILL?)/BI (S) 1000-1100/PRES
/RAD	Radioactivity	Bq (Becquerel)	S RAD?/BI (P) 10-100/RAD
/RES	Electrical Impedance/resistance	Ohm	S CERAMIC/CLM (P) 1-8/RES
/RSP	Rotational Speed	Revolution/Minute	S 7000-8000/RSP AND ENGINE
/SAR	Area /Surface Area	m <sup>2</sup>	S (COATING? OR FOIL?)/BI (S) 10- 100/SAR
/SOL	Solubility	Gram/100 gram	S SOL>20 (10W) WATER
/STSC	Surface Tension	J/m <sup>2</sup>	S 60 J/M**2 /STSC
/TCO	Thermal Conductivity	K (Kelvin)	S 30-40/TCO (S) THERMO?
/TEMP (or /T)	Temperature	K (Kelvin)	S (REACTION? (25A) PHOSPHAT?) (S) 10/TEMP
/TIM	Time	S (Second)	S ?INCUB?/CLM (10W) 10-50/TIM
/VEL (or /V)	Velocity	m/s (Metre per Second)	S PUMP?/BI (S) 1E-3-5E-3/VEL
/VELA	Velocity, angular	rpm	S ANG?/CLM (S) VELA>10
/VLR	Volumetric Flow Rate	Cubic Meter/Second	S 2-5/VLR (XA) TUBE
/VOL	Volume	m <sup>3</sup>	S ?FUSION?/BI (15A) 1E-8-2E-8 /VOL
/VOLT	Voltage	V (Volt)	S CALIBRAT?/BI(10A) 5E- 3<VOLT<7E-3

(1) Exponential format is recommended for the search of particularly high or low values, e.g. 1.8E+7 or 1.8E7 (for 18000000) and 9.2E-8 (for 0.00000092).

## DWPI Compound Numbers (/DCN) Thesaurus

For DWPI Compound Numbers (/DCN), the USE/UF relationships are available to see the definitions. All relationship codes can be used with both the EXPAND and SEARCH commands.

Field	Relationship Code	Content	Search Examples
/DCN	ALL UF USE	All associated terms (SELF, USE, UF) Used for terms (SELF, UF) Use terms (SELF, USE)	E R09609+ALL/DCN E R22401+UF/DCN E ACETIC ACID+USE/DCN

## DWPI Registry Numbers (/DRN) Thesaurus

For DWPI Registry Numbers (/DRN), the USE/UF relationships are available to see the definitions. All relationship codes can be used with both the EXPAND and SEARCH commands.

Field	Relationship Code	Content	Search Examples
/DRN	ALL UF USE	All associated terms (SELF, USE, UF) Used for terms (SELF, UF) Use terms (SELF, USE)	E 0495+ALL/DRN E 1314+UF/DRN E ACETIC ACID+USE/DRN

## Polymer Indexing Thesaurus

DWPI Polymer Indexing Thesaurus is available online in field /PLE. All relationship codes can be used with both the EXPAND and SEARCH commands.

Field	Relationship Code	Content	Search Examples
/PLE	ALL AUTO (1) BT HIE KT NT RT UF USE	All Associated Terms (BT, SELF, NOTE, USE, SEE, UF, NT, RT) Automatic Relationship (SELF, USE, UF) Broader Terms (also BT1=1 <sup>st</sup> Level, BT2=2 <sup>nd</sup> Level etc.) Hierarchy Terms (BT, SELF, NT) Keyword Terms (Multi-word Phrases containing the specified Keyword Term) Narrower Terms (also NT1=1 <sup>st</sup> Level, NT2=2 <sup>nd</sup> Level etc.) Related Terms (see also) Used for (Preferred and Forbidden Terms) Use (Forbidden and Preferred Terms)	E Q8457+ALL/PLE E CANS<APPLICATIONS>+ALL/PLE E BY-PRODUCTS/PLE S E4+AUTO E Q8457+BT/PLE E Q8399+HIE/PLE E POLYOL+KT/PLE E Q8399+NT/PLE E Q7034+RT/PLE E DIELECTRIC CONSTANT <PROPERTIES>+UF/PLE E POWER FACTOR/PLE

(1) Automatic Relationship is SET OFF. In case of SET REL ON the result of EXPAND or SEARCH without any relationship code is the same as described for AUTO.

## Plasdoc Key Serials Dictionary

The Plasdoc Key Serials codes in field /KS can be looked up in an online dictionary. You may expand on the definitions for the codes in field /KS, e.g., => E GASEOUS/KS will provide an alphabetical list around the term gaseous. The list also shows the number of codes associated with the term (AT column).

Field	Relationship Code	Content	Search Examples
/KS	ALL	All Associated Terms (CODE, DEF)	E GASEOUS+ALL/KS

## Manual Codes Thesauri (CPI AND EPI)

Field	Relationship Code	Content	Search Examples
/MC	ALL	All Associated Terms (BT, SELF, HNTE, DEF, NT)	E A03-A04A1+ALL/MC
	AUTO (1)	Automatic Relationship (SELF, HNTE, DEF)	E S01-B05+AUTO/MC
	BT	Broader Terms (BT, SELF)	E S06-B02A+BT/MC
	NT	Narrower Terms (NT, SELF)	S S06-B02+NT/MC

(1) Automatic Relationship is SET OFF. In case of SET REL ON the result of EXPAND or SEARCH without any relationship code is the same as described for AUTO.

## DWPI Title Terms

For the DWPI Title Terms, the preferred and controlled spelling of the words that occur in the title, the USE/UF (Used For) relationship is available for both the EXPAND and SEARCH commands. The automatic relationship is SET ON by default, so that forbidden terms will cause automatic retrieval of the preferred terms in a SEARCH.

Field	Relationship Code	Content	Search Examples
/TT	ALL	All Associated Terms (SELF, USE, UF)	E ABLATION+ALL/TT
	AUTO (1)	Automatic Relationship (SELF, USE)	S ABLATE+AUTO/TT
	UF	Used for (Preferred and Forbidden Terms - SELF, UF)	E FABRICATE+UF/TT
	USE	Use (Forbidden and Preferred Terms – SELF, USE)	S FABRICATED+USE/TT

(1) Automatic Relationship is SET OFF. In case of SET REL ON the result of EXPAND or SEARCH without any relationship code is the same as described for AUTO.

## Patent Assignee Code Dictionary

The list of Thomson Reuters (Professional) UK Ltd.-assigned company codes for patent assignees matched with company names is available in field /PACO. This feature allows you to easily and comprehensively identify the company names associated with a code, or to identify the code(s) used for a company name. Expanding in field /PACO (Patent Assignee Code) provides the alphabetical list of codes, single words and the full name from the company field (/PA). Each code is listed with its frequency in field /PACO and with the number of associated terms (AT) in the dictionary.

Field	Relationship Code	Content	Search Examples
/PACO	ALL DEF	All patent assignee code(s) defined for the name All name definitions for the given code	E BAYER+ALL/PACO E FARB+DEF/PACO

## IPC Thesaurus

The classifications and catchwords for the main headings and subheadings from the current (8<sup>th</sup>) edition of the WIPO International Patent Classification (IPC) manual are available. The classifications from the previous editions (1-7) are also available as separate thesauri. To EXPAND and SEARCH in the thesauri for editions 1-7, use the field code followed by the edition number, e.g., /IPC2, for the 2<sup>nd</sup> edition. Catchwords are included only in the thesauri for the 8<sup>th</sup>, 7<sup>th</sup>, 6<sup>th</sup>, and 5<sup>th</sup> editions.

Relationship Code	Content	Search Examples
ADVANCED (ADV) ALL BRO (MAN) BT CORE (COR) ED  HIE  INDEX KT NEXT NT PREV RT (SIB) TI	Advanced Codes for the Core Level IPC code All Associated Terms (BT, SELF, NT, RT) Complete Class Broader Term (SELF, BT) Core Codes for the Advanced Level IPC code Complete title of the SELF term and IPC manual edition Hierarchy Term (Broader and Narrower Term) (BT, SELF, NT) Complete title of the SELF term Keyword Term (catchwords) (SELF, KT) Next Classification Narrower Terms (SELF, NT) Previous Classification Related Terms (SELF, RT) Complete Title of the SELF Term and Broader Terms (BT, SELF)	E A61K006-02+ADV/IPC E C01C003-00+ALL/IPC E C01C+BRO/IPC E C01F001-00+BT/IPC E C03B0001-02+COR/IPC E C01F001-00+ED/IPC  E C011003-00+HIE/IPC  E C01F001-00+INDEX/IPC E CYANOGEN+KT/IPC E C01C001-00+NEXT5/IPC E C01C+NT/IPC E C01C001-12+PREV10/IPC E C01C003-20+RT/IPC E C01F001-00+TI/IPC

## F-Term (/FTERM) Thesaurus

This thesaurus is available in the F-Term (/FTERM) field that contains patent classification from the Japanese Patent Office from February 2009 to the present.

Relationship Code	Content	Search Examples
ALL BT CODE DEF HIE KT NT RFI TI	All associated terms (BT, SELF, NT, RT) Broader Term (SELF, BT) Code for the thesaurus text term Definition Hierarchy Terms (all broader and narrower terms) Keyword Term Narrower Term Related FI (File Indexing) classification Term Complete Title of the SELF Term and Broader Terms (BT, SELF)	E 2B002/AA05+ALL/FTERM E 2B002/AA05+BT/FTERM E 2B002/BA13+CODE/FTERM E 2B002/BA13+DEF/FTERM E 2B002/AA05+HIE/FTERM E 2B002/AA05+KT/FTERM E 2B002/AA09+NT/FTERM E 2B002/AA09+RFI/FTERM E 2B002/AA09+TI/FTERM

## FI-Term (/FCL) Thesaurus

This thesaurus is available in the FI-Term (/FCL) field that contains patent classification from the Japanese Patent Office.

Relationship Code	Content	Search Examples
ALL BT DEF HIE INDX MAX NOTE NT RT TI	All usually required associated terms Broader Term (SELF, BT) Definition Hierarchy Terms (all broader and narrower terms) Index Note All associated Terms Scope Notes Narrower Term Related Term Complete Title of the SELF Term and Broader Terms (BT, SELF)	E A01B0003-00+ALL/FCL E H02B0001-02+BT/FCL E H05B0041-392+DEF/FCL S H02B0001-02C+HIE/FCL E C07C CSP+INDX/FCL E B01B0001-08+MAX/FCL E B23D+NOTE/FCL E H05B0041-392+NT/FCL E H05B+RT/FCL E A01B0001-12+TI/FCL

## US National Patent Classification (/NCL) Thesaurus

The US National Patent Classification thesaurus is available online in field /NCL. All relationship codes can be used with both the EXPAND and SEARCH commands.

Relationship Code	Content	Search Examples
ALL AUTO (1) BT CODE DEF HIE KT MAX NEXT NEXT(n) NT PREV PREV(n) TI	All usually required terms (BT, SELF, DEF, NT) Automatic relationship (BT, SELF, DEF, NT) Broader Terms (BT, SELF) Classification Code (SELF, CODE) Definition (SELF, DEF, DEF2, DEF3, DEF4) Hierarchy Terms (BT, SELF, DEF, NT) Keyword Terms (SELF, KT) All associated Terms (BT, SELF, DEF, DEF2, DEF3, DEF4, NT, KT) Next classification within the same class Next n classifications within the same class Narrower Terms (SELF, NT) Previous Code within the same class Previous n classifications within the same class Complete title of the SELF and the Broader Terms including their definitions (BT (DEF), SELF, DEF)	E 257E21685+ALL/NCL E 02416300R+AUTO/NCL E 02416300R+BT/NCL E APPAREL+CODE/NCL E G9B031001+DEF/NCL E 23548700+HIE/NCL E APPAREL+KT/NCL E G9B031000+MAX/NCL  E G9B033035+NEXT/NCL E G9B033035+NEXT2/NCL S 257E21685+NT/NCL E 235462260+PREV/NCL E 235462260+PREV3/NCL E 052002110+TI/NCL

(1) Automatic Relationship is SET OFF. In case of SET REL ON the result of EXPAND or SEARCH without any relationship code is the same as described for AUTO.

## ECLA and ICO Thesauri

These thesauri are available in the /EPC search field (for ECLA codes) and /ICO search field ('in-computer-only') Classification. All relationship codes can be used with both the EXPAND and SEARCH commands.

Relationship Code	Content	Search Examples
ALL AUTO (1) BT CODE  DEF HIE  KT MAX NEXT	All usually required terms (BT, SELF, CODE, DEF) Automatic relationship (BT, SELF, CODE, DEF) Broader terms (BT, SELF) Classification Code (SELF, CODE)  Definition (SELF, DEF) Hierarchy terms (all broader and narrower terms) (BT, SELF, DEF, NT) Keyword terms (SELF, KT) All associated terms Next classification within the same class (SELF, NEXT)	E C12M0001-34H2+ALL/EPC E G01J003-443+AUTO/EPC E G01J0003-443+BT/EPC E SCRAPER BIASING MEANS+CODE/EPC E B65G0045-16+DEF/EPC E A01B0001+HIE/EPC  E LASER+KT/EPC E G01J0003-44B+MAX/EPC E A01B0001-24+NEXT/EPC

## ECLA and ICO Thesauri (cont'd)

Relationship Code	Content	Search Examples
NEXT(n) NT PREV PREV(n) TI	Next n classification within the same class Narrower term Previous Code within the same class (SELF, PREV) Previous n classifications within the same class Complete Title of the SELF Term and Broader Terms (BT, SELF)	E A01B0001-24+NEXT3/EPC S G05B0001-03+NT/EPC E L60H0001:00A+PREV/ICO E L60H0001:00A+PREV1/ICO E G05B0001-03+TI/EPC

(1) Automatic Relationship is SET OFF. In case of SET REL ON the result of EXPAND or SEARCH without any relationship code is the same as described for AUTO.

## DISPLAY and PRINT Formats

Any combination of formats may be used to display or print answers. Multiple codes must be separated by spaces or commas, e.g., D L1 1-5 TI AU. The fields are displayed or printed in the order requested.

Hit-term highlighting is available for all fields. Highlighting must be ON during SEARCH to use the HIT, KWIC, and OCC formats.

Format	Content	Examples
AB	Abstract (Basic)	D AB
ABDT (1)	Abstract, Documentation Type	D ABDT
ABEQ	Abstract, Equivalent	D ABEQ
ABEX (1)	Abstract, Extension	D ABEX
ACTN	Mechanism of Action	D ACTN
ACTV	Activity	D ACTV
ADT (2)	Application Details	D ADT
ADT.B (2)	Application Details, Basic	D ADT.B
ADV	Advantage	D ADV
AI (AP, AI.B) (2)	Application Information	D AI
ALE	Alerting Abstract, First Section	D ALE
AN	Accession Number	D AN
ANX	Crossover Accession Number	D ANX
AW	Additional Words	D AW
CC	Classification Code (Substance Descriptor)	D CC
CMC	Chemical Code	D CMC
CR (XR)	Cross Reference	D CR
CYC	Country Count	D CYC
DC	DWPI Class	D DC
DCN	DWPI Compound Number	D DCN
DN	Document Number (DNC and DNN)	D DN
DNC	Document Number CPI	D CNC
DNN	Document Number Non CPI	D DNN
DRN	DWPI Registry Number	D DRN
DRWN	Number of Drawings	D DRWN
DS	Designated State	D DS
DUPD	DWPI Update	D DUPD
ED	Entry Date	D ED
EPC (ECLA, EPCLA)	European Patent Classification	D EPC
FA	Field Availability	D FA
FCL (JPC)	Japanese Patent Office Classification (FI or File Index)	D FCL
FDT	Filing Details	D FDT
FG (AM)	Fragment Code	D FG
FS	File Segment	D FS
FTRM (FTERM, FTCLA, JPCLA)	Japanese Patent Office Classification (FTERM or File Forming Term)	D FTRM
GI	Graphic Information	D GI
GINF (GIS)	Graphic Image(s) Information	D GINF
IC	International Patent Classification	D IC
ICA	IPC, Additional (Supplementary)	D ICA

## DISPLAY and PRINT Formats (cont'd)

Format	Content	Examples
ICI	IPC, Index (Complementary)	D ICI
ICM	IPC, Main	D ICM
ICO	ICO (in-computer-only) Classification	D ICO
ICS	IPC, Secondary	D ICS
IN (AU)	Inventor	D IN
IPCI	IPC, Initial	D IPCI
IPCR	IPC, Reclassified	D IPCR
IT	Index Term	D IT
KS	Plasdoc Key Serials	D KS
M0-M6	Chemical Codes	D M0
MC	Manual Code	D MC
NCL	US National Patent Classification, Current	D NCL
NOV	Novelty	D NOV
PA (CS)	Patent Assignee (incl. code)	D PA
PI (2,3)	Patent Information (including designated states)	D PI
PI.B (PN.B) (2,3)	Patent Information, Basic	D PI.B
PIA (2)	Patent Information Abbreviated	D PIA
PIA.B (2)	Patent Information Abbreviated, Basic	D PIA.B
PLC	Polymer Coding Plasdoc	D PLC
PLE	Polymer Indexing Enhanced	D PLE
PN (2,3)	Patent Information (without designated states)	D PN
PNK	Patent Number/Kind Code	D PNK
PNK.B	Patent Number/Kind Code, Basic	D PNK.B
PNC	Patent Number Count	D PNC
PRAI (PRN) (2)	Priority Information	D PRAI
RIN	Ring Index Number	D RIN
TECH	Technology Focus	D TECH
TI	Title	D TI
TT	Title Terms	D TT
UADV	Use/Advantage Section	D UADV
UP	Update Date	D UP
UPA	Update Date Polymer Indexing	D UPA
UPAB	Update Date Abstract	D UPAB
UPB	Update Date Chemical Code	D UPB
UPDA	Update Date Documentation Abstract	D UPDA
UPEQ	Update Date Equivalent	D UPEQ
UPGI	Update Date Graphic Image	D UPGI
UPIT	Update Date Index Terms	D UPIT
UPPA	Update Date Patent Assignee	D UPPA
UPPI	Update Date Patent Information	D UPPI
UPPR	Update Date Priority Information	D UPPR
UPS	Update Date SDI	D UPS
UPTI	Update Date Enhanced Title	D UPTI
USE	Use	D USE

(1) This field is available in WPIX only.

(2) Application, priority and patent numbers are available in Derwent and STN format. The format for DISPLAY, PRINT, SELECT and SORT is controlled by the Messenger SET PATENT command. The STN format is default. 'SET PAT DERWENT' changes (permanently) to the Derwent format. To change to the STN format again, enter 'SET PAT STN'.

(3) Basic patents are identified with an asterisk (\*), Equivalent-Treated-as-Basic are identified with a capital letter B, and Non-Conventional Equivalents are identified with a hash mark (#).

## Bibliographic Segment Predefined Formats

Format	Content	Examples
ABS ALL (1)	AN, CR, AB, UPAB, ABEQ all invention level data available for a given record, excluding the Equivalent (ABEQ), Documentation (ABDT), and Extension (ABEX) abstracts and the chemical coding and polymer indexing: AN, CR, ANX, DNC, DNN, TI, DC, IN, PA, CYC, PI, ADT, FDT, PRAI, IPC, EPC, ICO, NCL, FCL, FTRM, AB, UPAB, FS, MC. Short compressed version.	D TI PA ABS

**Bibliographic Segment Predefined Formats (cont'd)**

Format	Content	Examples
ALLG (1) DALL (1) IALL (1) IALL.G (1) ANL APPS (1) BASIC (1)	ALL, plus graphic image ALL, delimited for post processing ALL, indented with text labels ALLG, indented with text labels Accession Number List only ADT, PRAI	D ALLG D DALL D IALL  D ANL D APPS
BIB (1) IBIB (1) BRIEF BRIEFG IBRIEF IBRIEFG FAM (1) FULL (1,2)	AN, CR, DNC, DNN, TI, DC, IN, PA, PNC, CYC, PI.B, ADT.B, PRAI, AB, UPAB, FS AN, CR, DNC, DNN, TI, DC, IN, PA, CYC, PIA, ADT, FDT, PRAI BIB, indented with text labels AN, CR, ANX, DNC, DNN, TI, DC, PA, AB, UPAB BRIEF, plus graphic image BRIEF, indented with text labels BRIEFG, indented with text labels PI, ADT, FDT, PRAI	D BIB D IBIB D BRIEF D BRIEFG D IBRIEF D IBRIEFG D FAM D FULL
FULLG (1,2) IFULL (1,2) IFULLG (1,2) CODE (IND) IPC IPC.TAB MAX (1,2)	all invention level data available for a given record plus Technology Focus (TECH) and Documentation (ABDT) or Extension abstracts (ABEX), excluding the Equivalent abstracts (ABEQ) and the chemical coding and polymer indexing: AN, CR, ANX, DNC, DNN, TI, DC, IN, PA, CYC, PI, ADT, FDT, PRAI, IPC, EPC, ICO, NCL, FCL, FTRM, AB, UPAB, FS, MC, TECH, ABDT, ABEX. Short compressed version. FULL, plus graphic image FULL, indented with text labels FULLG, indented with text labels AN, DC, IPC, EPC, FCL, FTRM, MC, IT, DRN, PLE, PLC, CMC IC (ICM, ICS), ICA, ICI, IPCI, IPCR International Patent Classification, in tabular version all invention level data available for a given record, including the chemical coding, and polymer indexing as well as Equivalent (ABEQ), Documentation (ABDT) and Extension (ABEX) abstracts: AN, ED, CR, ANX, DNC, DNN, TI, AW, DC, IN, PA, CYC, PI, ADT, FDT, PRAI, IPC, EPC, ICO, NCL, FCL, FTRM, AB, UPAB, SL, ABEQ, TECH, ABEX, ABDT, IT, FS, MC, DRN, PLE, PLC, CMC	D FULLG D IFULL D IFULLG D CODE D IPC D IPC.TAB D MAX
MAXG (1,2) IMAX (1,2) IMAXG (1,2) PATS (1) SCAN (3) STD (1)	MAX, plus GI, GINF MAX, indented with text labels MAXG, indented with text labels PI, FDT TI (random display, no answer numbers) AN, CR, DNC, DNN, TI, DC, IN, PA, CYC, PI, ADT, FDT, PRAI, IPC (STD is the default)	D MAXG D IMAX D IMAXG D PATS D SCAN D STD
ISTD (1) SUM TRIAL (TRI, SAMPLE, SAM) UPP XMLDOC (4)	STD, indented with text labels AN, TI, NOV AN, CR, ANX, DNC, DNN, TI, DC, IPC, EPC, ICO, MC  Update Patent Family (contains date plus patent family information) Retrieve documents in XML format	D ISTD D SUM D TRIAL  D UPP D XMLDOC
HIT HITCMC HITCODE HITMEMB HITPLC HITPLE HITSTR FRAGHITSTR  KWIC OCC	Hit term(s) and field(s) Hit chemical coding CMC, EPC, IPC, NCL, MC, PLC, PLE, containing hit terms All individual publications containing hit terms Hit polymer coding Hit polymer indexing DCR hit record which led to the retrieval of the bibliographic record DCR specific chemical structure for a fragment code hit records which led to the retrieval of bibliographic record Up to 50 words before and after hit term(s) (KeyWord-In-Context) Number of occurrences of hit term(s) and field(s) in which they occur	D HIT    D HITPLC 1-5  D HITSTR  D KWIC D OCC

- (1) Application, priority and patent numbers are available in Derwent and STN format. The format for DISPLAY, PRINT, SELECT and SORT is controlled by the Messenger SET PATENT command. The STN format is default. 'SET PAT DERWENT' changes (permanently) to the Derwent format. To change to the STN format again, enter 'SET PAT STN'.
- (2) ABDT and ABEX are available in WPIX only.
- (3) SCAN must be specified on the command line, i.e., D SCAN or DISPLAY SCAN.
- (4) Only valid in WPIX.

## Additional DWPI individual Patent Publication (often First Level Data) Display and Print Formats

Format	Content	Examples
ABDE	Abstract, Original, in German	D ABDE
ABEN	Abstract, Original, in English	D ABEN
ABES	Abstract, Original, in Spanish	D ABES
ABFR	Abstract, Original, in French	D ABFR
ABOL	Abstract, Original, other languages	D ABOL
AG	Agent	D AG
AG.T	Agent, Total	D AG.T
AGA	Agent Address	D AGA
AN.PUB	Accession Number, Publication Level	D AN.PUB
APTS	Application Information, Thomson Reuters (Professional) UK Ltd.	D APTS
CLM (MCLM)	Claims (CLMEN, CLMDE, CLMFR)	D CLM
CLMDE (1)	Claims, in German	D CLMDE
CLMEN (1)	Claims, in English	D CLMEN
CLMFR (1)	Claims, in French	D CLMFR
FS.M	File Segment (Individual Patent Publication Section)	D FS.M
GI.M	Graphic Information, Member Patent	D GI.M
IIC	Initial International Patent Classification (ICM, ICS)	D IIC
IICA	Initial IPC, Additional (supplementary)	D IICA
IICI	Initial IPC, Index (complementary)	D IICI
IICM	Initial IPC, Main	D IICM
IICS	Initial IPC, Secondary	D IICS
IN.T	Inventor, Total	D IN.T
INA	Inventor Address	D INA
INCL	National Classification, Issued	D INCL
INO	Inventor, Original	D INO
PA.T	Patent Assignee, Total	D PA.T
PAA	Patent Assignee Address	D PAA
PAO	Patent Assignee, Original	D PAO
PRTS	Priority Application Information, Thomson Reuters (Professional) UK Ltd.	D PRTS
TIDE	Title, Original, in German	D TIDE
TIEN	Title, Original, in English	D TIEN
TIES	Title, Original, in Spanish	D TIES
TIFR	Title, Original, in French	D TIFR

(1) Custom display only.

## Additional DWPI individual Patent Publication (often First Level Data) Predefined Formats

Format	Content	Examples
IPC.TAB.M MEMB (1)	International Patent Classification, in tabular version all additional publication level data available for a given record including original abstracts and claims, as well as fields showing publication level composition: PN, TIEN, TIDE, TIFR, TIES, AG, IN, INO, INA, PA, PAO, PAA, ADT, APTS, FDT, PRAI, PRTS, IPC, IIC, IICI, IICA, EPC.M, ICO.M, NCL.M, INCL, FCL, FTRM, ABEQ, ABEN, ABDE, ABFR, ABES, ABOL, CLM, UPCL, FS.M	D IPC.TAB.M D MEMB



## Chemistry Resource Segment Predefined Formats (cont'd)

Format	Content	Examples
MAX	AN.S, DCSE, CN, CN.S, STR, SCR, CMT, MF, SMF, MW, SRIN, SDCN, SDRN, DDRN, DCRN, CC, CT, SS	D MAX
IMAX	MAX, indented with text labels	D IMAX
SCAN (1)	CN, CN.S, MF, STR (random display without answer numbers)	D STD
STD (IDE)	AN.S, DCSE, CN, CN.S, STR, SCR, CMT, MF (STD is the default)	D STD
ISTD	STD, indented with text labels	D TRI 3-10
TRIAL (TRI, SAMPLE, SAM)	CN, CN.S, MF, MTY, STR	D TRI 3-10
HIT	Hit term(s) and field(s)	D HIT
KWIC	Up to 50 words before and after hit term(s) (KeyWord-In-Context)	D KWIC
OCC	Number of occurrences of hit term(s) and field(s) in which they occur	D OCC

(1) SCAN must be specified on the command line, i.e., D SCAN or DISPLAY SCAN.

## SELECT, ANALYZE, and SORT Fields

The SELECT command is used to create E-numbers containing terms taken from the specified field in an answer set.

The ANALYZE command is used to create an L-number containing terms taken from the specified field in an answer set.

The SORT command is used to rearrange the search results in either alphabetic or numeric order of the specified field(s).

Field Name	Field Code	ANALYZE/ SELECT (1)	SORT
Abstract (Basic)	AB	Y	N
Abstract, Documentation Type	ABDT	Y (2)	N
Abstract, Extension	ABEX	Y (2)	N
Accession Number	AN	Y	Y
Activity	ACTV	Y	Y
Additional Words	AW	Y (3)	Y
Advantage	ADV	Y	Y
Alerting Abstract, First Section	ALE	Y	Y
Application Country	AC	Y	N
Application Date	AD	Y	N
Application Number	AP (AI, ADT)	Y (4)	N
Application Number Group	APPS	Y (4,5)	N
Application Number, Year	AP.YR	Y	N
Application Year	AY	Y	N
Chemical Codes	M0-M6	Y	Y
Chemical Resource Number	DCR	Y	N
Chemical Resource Number, without role	DCR.WR	Y	N
Chemical Resource Number, without role, with DCR-prefix	DCR.WRS	Y (6)	N
Country Count	CYC	Y	Y
Cross Reference	CR (XR)	Y	N
Crossover Accession Number	ANX	Y	N
Designated State	DS	Y	N
Document Number	DN	Y (7)	N
Document Number CPI	DNC	Y	Y
Document Number Non CPI	DNN	Y	Y
DWPI Class	DC	Y	Y
DWPI Registry Number	DRN	Y	N
DWPI Update	DUPD	Y	Y
DWPI Week	DW	Y (8)	Y
DWPI Week, Basic	DW.B	Y (8)	N

**SELECT, ANALYZE, and SORT Fields (cont'd)**

Field Name	Field Code	ANALYZE/ SELECT (1)	SORT
Entry Date	ED	Y	Y
European Patent Classification	EPC (ECLA, EPCLA)	Y	N
File Segment	FS	Y	Y
Filing Details	FDT	Y	N
Filing Details, Patent Country	FDT.PC (RLPC)	Y	N
Filing Details, Patent Kind	FDT.PK (RLPK)	Y	N
Filing Details, Patent Number	FDT.PN (RLPN)	Y	N
Filing Details, Type	FDT.TP	Y	N
Fragment Code	FG (AM)	Y	Y
Graphic Information Size	GIS	Y	N
ICO (in-computer-only) Classification	ICO	Y	Y
International Patent Classification (ICM, ICS, ICA, ICI, IPCI, PCR, IICM, IICS, IICA, IICI)	IPC	Y	N
Inventor	IN (AU)	Y	Y
IPC Advanced Level	IPC.A	Y (9)	N
IPC Advanced Level, Invention	IPC.AI	Y (9)	N
IPC Core Level	IPC.C	Y (9)	N
IPC Core Level, Invention	IPC.CI	Y (9)	N
IPC Reform	IPC.REF	Y	N
IPC, Additional (supplementary)	ICA	Y	Y
IPC, Index (complementary)	ICI	Y	Y
IPC, Initial	IPCI	Y (10)	N
IPC, Main	ICM	Y	Y
IPC, Main and Secondary	IC	Y	Y
IPC, Main or First	IPC.F	Y (9)	Y
IPC, Reclassified	IPCR	Y (10)	N
IPC, Secondary	ICS	Y	N
Japanese Patent Office Classification (FI Class) (Additional)	FACL	Y	N
Japanese Patent Office Classification (FI Class) (Index)	FICL	Y	N
Japanese Patent Office Classification (FI Class) (Main)	FMCL	Y	N
Japanese Patent Office Classification (FI Class) (Secondary)	FSCL	Y	N
Japanese Patent Office Classification (FI or File Index)	FCL (JPC)	Y	N
Japanese Patent Office Classification (FTERM or File Forming Term)	FTRM (FTERM, FTCLA, JPCLA)	Y	N
Language	LA	Y (8)	N
Manual Code	MC	Y	N
Markush Compound Number	MCN	Y	Y
Mechanism of Action	ACTN	Y	Y
Novelty	NOV	Y	Y
Number of Drawings	DRWN	Y	Y
Occurrence Count of Hit Terms	OCC	N	Y
Patent Assignee	PA (CS)	Y	Y
Patent Assignee Code	PACO	Y	Y
Patent Assignee Code and Name	PAX	Y	N
Patent Countries	PCS	Y (11)	N
Patent Country	PC	Y	N
Patent Country, Basic	PC.B	Y	Y
Patent Number Group	PATS	Y (12)	Y
Publication Date	PD	Y	Y
Publication Date, Basic	PD.B	Y	Y
Patent Information Abbreviated	PIA	Y (13)	N
Patent Information Abbreviated, Basic	PIA.B	Y (14)	Y
Patent Kind Code	PK	Y	Y
Patent Kind Code, Basic	PK.B	Y	Y
Patent Number	PN (PI)	Y (5)	Y
Patent Number Count	PNC	Y	Y

**SELECT, ANALYZE, and SORT Fields (cont'd)**

Field Name	Field Code	ANALYZE/ SELECT (1)	SORT
Patent Number, Basic	PN.B (PI.B)	Y (5)	Y
Patent Number/Kind Code	PNK	Y	N
Patent Number/Kind Code, Basic	PNK.B	Y	N
Polymer Indexing Enhanced	PLE	Y	N
Priority Country	PRC	Y	N
Priority Date	PRD	Y	N
Priority Date First	PRDF	Y	Y
Priority Number	PRN (PRAI)	Y (5)	Y
Priority Year	PRY	Y	Y
Priority Year First	PRYF	Y	N
Publication Year	PY	Y	Y
Publication Year, Basic	PY.B	Y	Y
Ring Index Number	RIN	Y	Y
Subclass	SCL	Y (15)	N
Subclass Additional	SCLA	Y (16)	N
Subclass Group	SCG	Y (15)	N
Subclass Group Additional	SCGA	Y (16)	N
Subclass Group Main	SCGM	Y (17)	N
Subclass Group Secondary	SCGS	Y (16)	N
Subclass Main	SCLM	Y (17)	N
Subclass Secondary	SCLS	Y (18)	N
Technology Focus	TECH	Y	N
Title	TI	Y (default)	Y
Title Terms	TT	Y	N
Update Date	UP	Y	Y
Update Date Abstract	UPAB	Y	Y
Update Date Chemical Code	UPB	Y	Y
Update Date Documentation Abstract	UPDA	Y	Y
Update Date Enhanced Title	UPTI	Y	Y
Update Date Graphic Image	UPGI	Y	Y
Update Date Index Terms	UPIT (UPKW)	Y	Y
Update Date Patent Assignee	UPPA	Y	Y
Update Date Patent Family	UPP	Y	Y
Update Date Patent Information	UPPI	Y	Y
Update Date Polymer Code (PLC and PLE)	UPA	Y	Y
Update Date Priority Information	UPPR	Y	Y
Use Section	USE	Y	Y
US National Patent Classification, Current	NCL	Y	Y
US National Patent Classification, Current (main)	NCLM	Y (19)	N
US National Patent Classification, Current (secondary)	NCLS	Y (19)	N
Use/Advantage Section	UADV	Y	Y

- (1) HIT may be used to restrict terms extracted to terms that match the search expression used to create the answer set, e.g., SEL HIT TI.
- (2) Field valid in WPIX only.
- (3) Appends /TT to the terms created by SELECT.
- (4) SELECTed, ANALYZed and SORTed application, priority and patent numbers are in the format set by the Messenger SET PATENT command, either Derwent or STN.
- (5) Selects or analyzes application and priority numbers and appends /APPS to the terms created by SELECT.
- (6) Appends /AN.S to the terms created by SELECT
- (7) Selects or analyzes DNC and DNN with /DN appended to the terms created by SELECT.
- (8) SELECT HIT or ANALYZE HIT are not valid with this field.
- (9) Appends /IPC to the terms created by SELECT.
- (10) Appends /IPC.REF to the terms created by SELECT.
- (11) Selects or analyzes patent countries and designated states and appends /PCS to the terms created by SELECT.
- (12) Selects or analyzes patent number and filing details and appends /PATS to the terms created by SELECT.
- (13) Selects or analyzes patent numbers with /PN appended to the terms created by SELECT.
- (14) Selects or analyzes basic patent numbers with /PN.B appended to the terms created by SELECT.
- (15) Appends /IC to the terms created by SELECT.
- (16) Appends /ICA to the terms created by SELECT.
- (18) Appends /ICM to the terms created by SELECT.
- (17) Appends /ICS to the terms created by SELECT.
- (19) Appends /NCL to the terms created by SELECT.

## Additional DWPI individual Patent Publication (often First Level Data) SELECT, ANALYZE, and SORT Fields

Field Name	Field Code	ANALYZE/ SELECT (1)	SORT
Abstract, Original, in English	ABEN	Y (2)	N
Abstract, Original, in French	ABFR	Y (2)	N
Abstract, Original, in German	ABDE	Y (2)	N
Abstract, Original, in Spanish	ABES	Y (2)	N
Abstract, Original, other languages	ABOL	Y (2)	N
Accession Number, Publication Level	AN.PUB	Y	N
Agent	AG	Y	Y
Agent Address	AGA	Y	Y
Agent Address, City	AGA.CTY	Y	Y
Agent Address, Country	AGA.CNY	Y	Y
Agent, Total	AG.T	Y	Y
Application Information, Thomson Reuters (Professional) UK Ltd.	APTS	Y	N
Claims in English	CLMEN	Y (2)	N
Claims in French	CLMFR	Y (2)	N
Claims in German	CLMDE	Y (2)	N
Field Availability (Individual Patent Publication Section)	FA.M	Y	N
File Segment (Individual Patent Publication Section)	FS.M	Y	Y
Initial IPC, Subclass	ISCL	Y	N
Initial IPC, Subclass Additional	ISCLA	Y	N
Initial IPC, Subclass Group	ISCG	Y	N
Initial IPC, Subclass Group Additional	ISCGA	Y	N
Initial IPC, Subclass Group Secondary	ISCGS	Y	N
Initial IPC, Subclass Main	ISCLM	Y	N
Inventor Address	INA	Y	Y
Inventor Address, City	INA.CTY	Y	Y
Inventor Address, Country	INA.CNY	Y	Y
Inventor, Nationality	IN.NAT	Y	Y
Inventor, Original	INO	Y	Y
Inventor, Total	IN.T	Y	Y
IPC, Initial	IIC	Y	Y
IPC, Initial, Additional (supplementary)	IICA	Y	Y
IPC, Initial, Index (complementary)	IICI	Y	Y
Main Claim	MCLM (CLM)	Y	N
National Classification, Issued	INCL	Y	Y
National Classification, Issued (main)	INCLM	Y	N
National Classification, Issued (secondary)	INCLS	Y	Y
Patent Assignee Address	PAA	Y	Y
Patent Assignee Address, City	PAA.CTY	Y	Y
Patent Assignee Address, Country	PAA.CNY	Y	Y
Patent Assignee, Limitation	PA.LIM	Y	Y
Patent Assignee, Nationality	PA.NAT	Y	Y
Patent Assignee, Original	PAO	Y	Y
Patent Assignee, Residence	PA.RES	Y	Y
Patent Assignee, Total	PA.T	Y	Y
Priority Application Information, Thomson Reuters (Professional) UK Ltd.	PRTS	Y	N
Title, Original, in English	TIEN	Y	Y
Title, Original, in French	TIFR	Y	Y
Title, Original, in German	TIDE	Y	Y
Title, Original, in Spanish	TIES	Y	Y

(1) HIT may be used to restrict terms extracted to terms that match the search expression used to create the answer set, e.g. SEL HIT TIDE.

(2) Appends /BIEX to the terms created by SELECT.

## Chemistry Resource Segment SELECT, ANALYZE, and SORT Fields

Field Name	Field Code	ANALYZE/ SELECT (1)	SORT
Chemical Name	CN	Y (2)	N
Chemical Name, Preferred	CN.P	Y	N
Chemical Name, Systematic	CN.S	Y	N
Chemistry Resource Accession Number, Chemistry Resource Segment	AN.S	Y	N
Chemistry Resource Number, Chemistry Resource Segment	DCSE	Y	Y
Classification Code	CC	Y	N
Comment	CMT	Y	N
Controlled Term	CT	Y	-
Derwent Drug Registry Name	DDRN	Y	-
Entry Date Chemistry Resource	EDCR	Y	Y
Index Term	IT	Y	N
Molecular Weight	MW	Y	Y
Standardized Molecular Formula	SMF	Y	N
Structure Cross Reference	SCR	Y	N
Structure Segment DWPI Compound Number	SDCN	Y	Y
Structure Segment DWPI Registry Number	SDRN	Y	Y
Structure Segment Ring Index Number	SRIN	Y	N
Substructure Term	SS	Y	N
Synonym Name	SY	Y (3)	N
Update Date Chemistry Resource	UPCR	Y	Y
Update Date DWPI Cross Reference	UPWX	Y	Y

(1) HIT may be used to restrict terms extracted to terms that match the search expression used to create the answer set, e.g. SEL HIT CN.

(2) Selects or analyzes CN.P and SY with /CN appended to the terms created by SELECT.

(3) Selects or analyzes CN.P and SY with /SY appended to the terms created by SELECT.

## Sample Records

### DISPLAY IFULLG

ACCESSION NUMBER: 2000-430976 [200037] WPIDS  
 DOC. NO. CPI: C2000-130861 [200037]  
 DOC. NO. NON-CPI: N2000-321671 [200037]  
 TITLE: Self-healing roll for surface conditioning of sheets,  
 e.g. metal sheets, has non-woven web elements comprising  
 entangled fibers held together by a bonding agent  
 DERWENT CLASS: A88; F04; M12; P51; P73; Q62  
 INVENTOR: BARBER L L; YOUNG J B  
 PATENT ASSIGNEE: (MINN-C) 3M INNOVATIVE PROPERTIES CO  
 COUNTRY COUNT: 20

### PATENT INFORMATION:

PATENT NO	KIND	DATE	WEEK	LA	PG	MAIN	IPC
WO 2000030778	A1	20000602	(200037)*	EN	25[3]		
EP 1135220	A1	20010926	(200157)	EN			
US 6300261	B1	20011009	(200162)	EN			
EP 1135220	B1	20020904	(200266)	EN			
DE 69902811	E	20021010	(200274)	DE			
JP 2002530544	W	20020917	(200276)	JA	24		

## WPIDS / WPINDEX / WPIX

## APPLICATION DETAILS:

PATENT NO	KIND	APPLICATION	DATE
WO 2000030778	A1	WO 1999-US24138	19991014
US 6300261	B1	US 1998-197132	19981120
DE 69902811	E	DE 1999-69902811	19991014
EP 1135220	A1	EP 1999-952014	19991014
EP 1135220	B1	EP 1999-952014	19991014
DE 69902811	E	EP 1999-952014	19991014
EP 1135220	A1	WO 1999-US24138	19991014
EP 1135220	B1	WO 1999-US24138	19991014
DE 69902811	E	WO 1999-US24138	19991014
JP 2002530544	W	WO 1999-US24138	19991014
JP 2002530544	W	JP 2000-583649	19991014

## FILING DETAILS:

PATENT NO	KIND	PATENT NO
DE 69902811	E	EP 1135220 A
EP 1135220	A1	WO 2000030778 A
EP 1135220	B1	WO 2000030778 A
DE 69902811	E	WO 2000030778 A
JP 2002530544	W	WO 2000030778 A

PRIORITY APPLN. INFO: US 1998-197132 19981120

INT. PATENT CLASSIF.:

MAIN: D04H001-58

IPC RECLASSIF.: B21B0045-02 [I,A]; B21B0045-02 [I,C]; B32B0005-22 [I,C];  
B32B0005-26 [I,A]; C23G0003-02 [I,A]; C23G0003-02 [I,C];  
D04H0001-58 [I,A]; D04H0001-58 [I,C]; F16C0013-00 [I,A];  
F16C0013-00 [I,C]

ECLA: B21B0045-02R4L; B32B0005-26; B32B0037-00; C23G0003-02T6;  
F16C0013-00

ICO: L32B0031:00D2; L32B0305:20; L32B0309:12

USCLASS NCLM: 442/328.000

NCLS: 428/912.000; 442/329.000; 442/337.000; 442/417.000

JAP. PATENT CLASSIF.:

MAIN/SEC.: D04H0001-58 A; F16C0013-00 A

FTERM CLASSIF.: 3J103; 4L047; 3J103/AA02; 4L047/BA03; 4L047/BA16;  
4L047/BC02; 4L047/BC08; 4L047/BC13; 4L047/CA05;  
4L047/CB10; 4L047/CC08; 4L047/DA00; 3J103/EA02;  
3J103/EA09; 3J103/EA13; 3J103/FA14; 3J103/FA15;  
3J103/FA30; 3J103/GA02; 3J103/HA19; 3J103/HA60

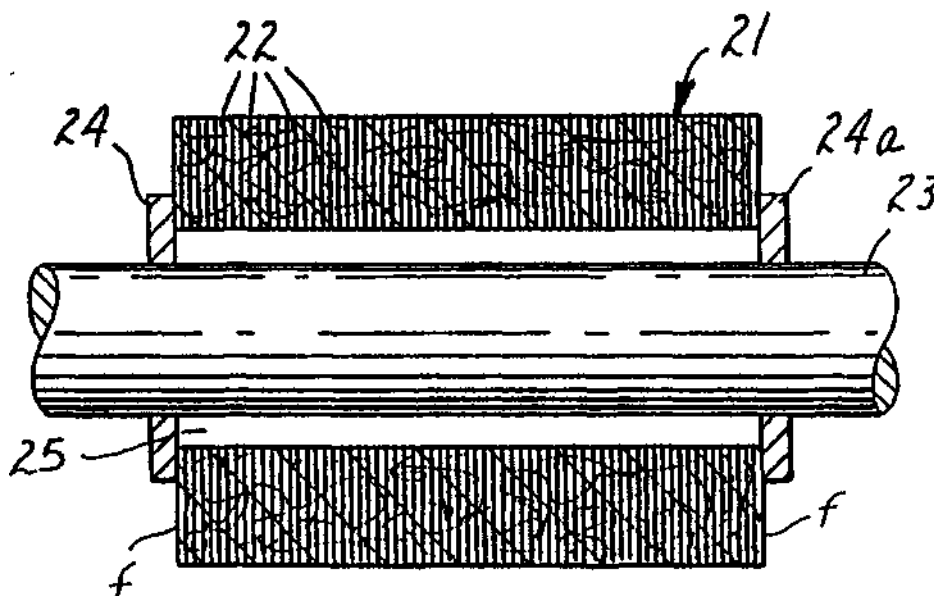

## BASIC ABSTRACT:

WO 2000030778 A1 UPAB: 20060116

NOVELTY - A self-healing article e.g. in the form of roll (21) comprises several compacted stacked web elements (22) having entangled fibers bonded together at points of mutual contact by a bonding agent. The article is resistant to an oxidizing agent and has a Shore A hardness of 70-93 and a void volume of 2-30%.

DETAILED DESCRIPTION - An INDEPENDENT CLAIM is also included for a method of making a self-healing and non-woven article comprising (i) providing several non-woven web elements comprising entangled fibers bonded at points of mutual contact by a bonding agent; (ii) stacking into a pile; (iii) compacting under a compaction force; and (iv) restraining the pile to form the self-healing article.

USE - For surface conditioning of sheets, e.g. metal sheets.

ADVANTAGE - The invention provides a self-healing article resistant to oxidizing agents having an increased life span. If used, results in fewer roll replacements and unscheduled production line downtimes. Chances of chemical contamination between treating solutions are also minimized.

DESCRIPTION OF DRAWINGS - The figure shows a partial cross-sectional view of a roll disposed on a keyed shaft.

Roll (21)

Compacted stacked non-woven web elements (22) TECHNOLOGY FOCUS:

POLYMERS - Preferred Agent: The bonding agent is nitrile rubber, polychloroprene, styrene butadiene rubber, polysulfide, silicone and/or polyepichlorohydrin (preferably nitrile rubber having a glass transition temperature of -30 - 10 degreesC).

METALLURGY - Preferred Method: The non-woven web is added with water prior to compacting.

FILE SEGMENT:

CPI; GMPI

MANUAL CODE:

CPI: A11-B05; A11-C05A; A12-H11; A12-S05G; A12-S05U;  
F02-C01; F02-C02B1; M12-A04

**WPIDS / WPINDEX / WPIX****DISPLAY MEMB(1)**

Member(0001)

PI WO 2000030778 A1 20000602 (200037)\* EN 25[3]

TIEN SELF-HEALING ARTICLES RESISTANT TO OXIDIZING AGENTS

TIFR ARTICLES DE REGENERATION RESISTANT AUX AGENTS D'OXYDATION

AG BUSSE, Paul, W.

AGA: 3M Innovative Properties Company, Office of Intellectual Property  
Counsel, P.O. Box 33427, Saint Paul, MN 55133-3427, US

IN YOUNG J B

INO: YOUNG, John, B.

INA: P.O. Box 33427, Saint Paul, MN 55133-3427, US

BARBER L L

INO: BARBER, Loren, L.

INA: P.O. Box 33427, Saint Paul, MN 55133-3427, US

PA (MINN-C) 3M INNOVATIVE PROPERTIES CO

PAO: 3M INNOVATIVE PROPERTIES COMPANY

PAA: 3M Center, P.O. Box 33427, Saint Paul, MN 55133-3427, US

Residence: US

Nationality: US

ADT WO 2000030778 A1 WO 1999-US24138 19991014

APTS 1999WO-US0024138

PRAI US 1998-197132 19981120

PRTS 1998US-000197132 19981120

IPCR Current: B21B0045-02 [I,A]; B21B0045-02 [I,C]; B32B0005-22 [I,C];  
B32B0005-26 [I,A]; C23G0003-02 [I,A]; C23G0003-02 [I,C]; D04H0001-58  
[I,A]; D04H0001-58 [I,C]; F16C0013-00 [I,A]; F16C0013-00 [I,C]

IIC IICM B21B045-02

IICS B32B003-08; B32B005-26; B32B031-10; B32B033-00; C23G003-02;  
D04H013-00; F16C013-00

EPC B21B0045-02R4L; B32B0005-26; B32B0037-00; C23G0003-02T6; F16C0013-00

ICO L32B0031:00D2; L32B0305:20; L32B0309:12

ABEN Self-healing articles resistant to oxidizing agents and useful for surface conditioning of sheets, especially metal sheets, are described. The articles (21) comprise a plurality of compacted, stacked non-woven web elements (2, 22), the web elements each comprising entangled fibers bonded together at points of mutual contact by a bonding agent. The article is resistant to an oxidizing agent or agents, has a Shore A hardness in the range of 70 to 93 and a void volume in the range of 2 to 30 percent. The non-woven articles can be configured into any of a variety of convenient and useful shapes, such as roll shapes, slab or bar shapes. The methods of making these articles are also described.

ABFR L'invention porte sur des articles de regeneration resistant aux agents d'oxydation et utiles pour le conditionnement en surface de feuilles, notamment de feuilles metalliques. Les articles (21) comprennent une pluralite d'elements (2, 22) de bande non tissee empiles, comprimes, comprenant chacun des fibres enchevetrees reliees en des points de contact mutuels par un agent de liaison. L'article est resistant aux agents d'oxydation, a une durete Shore A comprise entre 70 et 93 et un volume vide compris entre 2 et 30%. Les articles non tissés peuvent avoir une variete de formes pratiques et utiles telles que des rouleaux, des plaques et des barres. L'invention porte egalement sur des procedes de fabrication de ces articles.

## DISPLAY ALL DCR SEGMENT

AN.S DCR-1000003

DCSE 1000003-0-0-0

CN.S Acrylic acid 3-({[(dicyclohexylcarbamoyl)-methoxy]-acetyl}-phenyl-amino)-phenyl ester

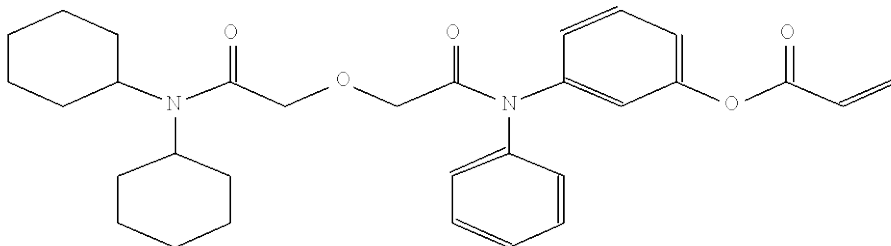

MF C31 H38 N2 O5

SMF C31 H38 N2 O5 \*1; TOTAL \*1; TYPE \*1

MW 518.6589

SDCN RAG9YE

CC UNSATURATED FATTY ACIDS

**In North America**

CAS  
STN North America  
P.O. Box 3012  
Columbus, Ohio 43210-0012 U.S.A.

CAS Customer Center:  
Phone: 800-753-4227 (North America)  
614-447-3700 (worldwide)  
Fax: 614-447-3751  
E-mail: help@cas.org  
Internet: www.cas.org

**In Europe**

FIZ Karlsruhe  
STN Europe  
P.O. Box 2465  
76012 Karlsruhe  
Germany  
Phone: +49-7247-808-555  
Fax: +49-7247-808-259  
E-mail: helpdesk@fiz-karlsruhe.de  
Internet: www.stn-international.com

**In Japan**

JALCI (Japan Association for  
International Chemical Information)  
STN Japan  
Nakai Building  
6-25-4 Honkomagome, Bunkyo-ku  
Tokyo 113-0021, Japan  
Phone: +81-3-5978-3601 (Technical Service)  
+81-3-5978-3621 (Customer Service)  
Fax: +81-3-5978-3600  
E-mail: support@jaici.or.jp (Technical Service)  
customer@jaici.or.jp (Customer Service)  
Internet: www.jaici.or.jp